

# Microgrid: A Conceptual Solution

Robert H. Lasseter, Paolo Piagi  
University of Wisconsin-Madison  
Madison, Wisconsin  
Email: [lasseter@engr.wisc.edu](mailto:lasseter@engr.wisc.edu)

**Abstract**— Application of individual distributed generators can cause as many problems as it may solve. A better way to realize the emerging potential of distributed generation is to take a system approach which views generation and associated loads as a subsystem or a “microgrid”. During disturbances, the generation and corresponding loads can separate from the distribution system to isolate the microgrid’s load from the disturbance (providing UPS services) without harming the transmission grid’s integrity. This ability to island generation and loads together has a potential to provide a higher local reliability than that provided by the power system as a whole. In this model it is also critical to be able to use the waste heat by placing the sources near the heat load. This implies that a unit can be placed at any point on the electrical system as required by the location of the heat load.

**Index:** microgrid, distributed generation, CHP, intentional islanding, voltage droop, power vs. frequency droop, inverters

## I. INTRODUCTION

Economic, technology and environmental incentives are changing the face of electricity generation and transmission. Centralized generating facilities are giving way to smaller, more distributed generation partially due to the loss of traditional economies of scale.

Penetration of distributed generation across the US has not yet reached significant levels. However that situation is changing rapidly and requires attention to issues related to high penetration of distributed generation within the distribution system.

Distributed generation encompasses a wide range of prime mover technologies, such as internal combustion (IC) engines, gas turbines, microturbines, photovoltaic, fuel cells and wind-power. Most emerging technologies such as micro-turbines, photovoltaic, fuel cells and gas internal combustion engines with permanent magnet generator require an inverter to interface with the electrical distribution system. These emerging technologies have lower emissions and the potential to have lower cost negating traditional economies of scale. The applications include power support at substations, deferral of T&D upgrades and onsite generation.

Indiscriminant application of individual distributed generators can cause as many problems as it may solve. A better way to realize the emerging potential of distributed generation is to

take a system approach which views generation and associated loads as a subsystem or a “microgrid”. This approach allows for local control of distributed generation thereby reducing or eliminating the need for central dispatch. During disturbances, the generation and corresponding loads can separate from the distribution system to isolate the microgrid’s load from the disturbance (and thereby maintaining high level of service) without harming the transmission grid’s integrity. Intentional islanding of generation and loads have the potential to provide a higher local reliability than that provided by the power system as a whole. The smaller size of emerging generation technologies permits generators to be placed optimally in relation to heat loads allowing for use of waste heat. Such applications can more than double the overall efficiencies of the systems.

Most current microgrid implementations combine loads with sources, allow for intentional islanding and try to use the available waste heat. These solutions rely on complex communication and control and are dependent on key components and require extensive site engineering. Our approach is to provide generator-based controls that enable a plug-and-play model without communication or custom engineering for each site.

## II. EMERGING GENERATION TECHNOLOGIES

Distributed-power applications favor natural-gas technologies due to the potential of low air emissions. Diesel-fueled systems still dominate in standby and short-run applications, but currently natural gas is better at combining availability, price and environmental compliance.

Reciprocating engine technology has been driven by economic and environmental pressures for power-density improvements, increased fuel efficiency and reduced emissions. Emissions of natural-gas engines have improved significantly through better design and control of the combustion process. Advanced lean-burn natural-gas engines produce nitrogen oxide (NOx) levels as low as 50 ppmv, which is an enormous improvement but in most applications still requires the use of exhaust catalysts. Efficiencies are around 39% with a goal of 50%. Unfortunately high efficiency and low emissions are not currently achieved simultaneously.

Microturbines are an important emerging technology. They are mechanically simple, single shaft devices with air bearings

and no lubricants. They are designed to combine the reliability of commercial aircraft auxiliary power units with the low cost of automotive turbochargers. The generator is usually a permanent magnet machine operating at variable speeds (50,000-100,000 rpm). This variable speed operation requires power electronics to interface to the electrical system. Examples include; Capstone's 30-kW and 60- kW systems and products from European manufacturers Bowman and Turbec. Sophisticated combustion systems, low turbine temperatures and lean fuel-to-air ratios results in NOx emissions of less than 10 ppmv and inherently low-carbon monoxide emissions. Larger gas turbines, reciprocating engines, and reformers all involve higher temperatures that result in much higher NOx production. Microturbines can operate using a number of different fuels including natural-gas and such liquid fuels as gasoline with efficiencies in the 28-30% range.

Fuel cells, which produce electricity from hydrogen and oxygen, emit only water vapor. NOx and CO<sub>2</sub> emissions are associated with the reforming of natural gas or other fuels to produce the fuel cell's hydrogen supply. Fuel cells offer higher efficiency than microturbines with low emissions but are currently expensive. Phosphoric acid cells are commercially available in the 200-kW range, and high temperature solid-oxide and molten-carbonate cells have been demonstrated and are particularly promising for distributed applications. A major development effort by automotive companies has focused on the possibility of using on-board reforming of gasoline or other common fuels to hydrogen, to be used in low temperature proton exchange membrane (PEM) fuel cells. Automotive fuel cells will have a major impact on stationary power if the automotive cost goal of \$100/kW is achieved.

### III. TOTAL SYSTEM EFFICIENCY

Most existing power plants, central or distributed, deliver electricity to user sites at an overall fuel-to-electricity efficiency in the range of 28-32%. This represents a loss of around 70% of the primary energy provided to the generator. To reduce this energy loss it is necessary to either increase the fuel-to-electricity efficiency of the generation plant and/or use the waste heat.

Combined power cycles technology can attain efficiencies approaching 60% with ratings in the hundreds of million watts [1]. On the other hand if the waste heat from generators with much lower efficiency (28-32%) can be utilized through heat exchangers, absorption chillers and/or desiccant dehumidification the overall fuel-to-useful energy efficiency can be higher than 80%. Currently Capstone markets a 60kW microturbine using waste heat to heat water. This system has a fuel to useful energy efficiency approaching 90% [2].

This use of waste heat through co-generation or combined heat and power (CHP) implies an integrated energy system, which delivers both electricity and useful heat from an energy source such as natural gas [3]. Unlike electricity, heat, usually in the

form of steam or hot water, cannot be easily or economically transported long distances, so CHP systems typically provide heat for local use. Because electricity is more readily transported than heat, generation of heat close to the location of the heat load will usually make more sense than generation of heat close to the electrical load.

The size of emerging generation technologies permits generators to be placed optimally in relation to heat loads. The scale of heat production for individual units is small and therefore offers greater flexibility in matching to heat requirements. An ideal system could be constructed from the most economic combination of waste-heat-producing generators and non-waste-heat producing generators so that the combined generation of electricity and heat is optimized. In an extreme example, fuel cells could be placed on every floor of a hospital to meet each floor's hot water needs and provide electricity to local loads.

For stationary energy users needing both electricity and useful heat there are two basic systems available: separate generation of electricity and heat, and combined heat and power (CHP) systems located near the heat load. To find the total energy efficiency for systems with separate generation of electricity and heat the generation efficiencies as well as the loading ratio of thermal energy-to-electrical energy needs to be known. For CHP systems the electrical and thermal recovery efficiencies along with the maximum loading level are required.

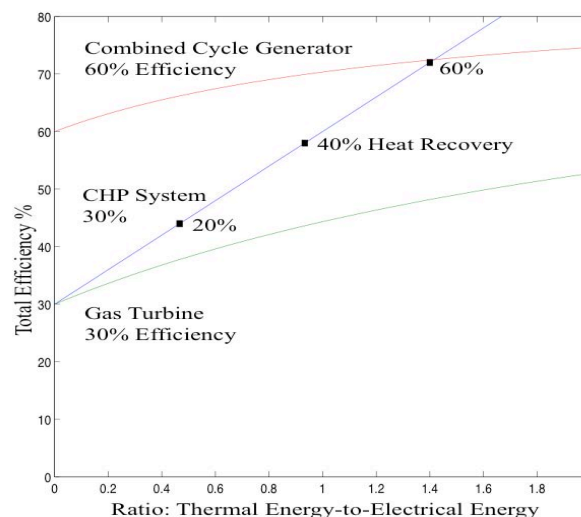

Figure 1. Total Energy Efficiency

Figure 1 illustrates the total energy efficiency as a function of the loading ratio for different systems. Two systems assume separate generation of electricity and heat, the third is a CHP system. The assumed thermal generation efficiency for the

non-CHP examples is 85%, while the electrical efficiencies are 60% and 30% respectively. If a loading ratio of one is assumed the overall efficiencies of the separate systems are 70% and 44%.

For the case where the waste heat is near the heat load the waste heat can be used instead of fuel to provide the required heat. Typical thermal recovery efficiencies can range from 20% to 80%. Unlike separate systems for heat and electricity the maximum loading ratio is limited. For example if the electrical efficiency is 30% resulting in 70% of the fuel being waste heat. If this waste heat can be converted to useful heat assuming a thermal recovery efficiency of 40% the total energy efficiency is 58% with a loading (ratio of thermal energy-to-electrical energy) of 1.00. This is the *maximum loading and maximum total efficiency* for this particular system. If the system is not loaded to this level the total efficiency drops linearly. It is apparent from figure 1 that CHP systems can greatly improve the total energy efficiency depending on loading levels and the thermal recovery efficiencies. Note that three thermal recovery efficiencies are shown on the plot for the CHP system.

#### IV. MICROGRID CONCEPT

To realize the emerging potential of distributed generation one must take a system approach which views generation and associated loads as a subsystem or a “microgrid” [4]. During disturbances, the generation and corresponding loads can separate from the distribution system to isolate the microgrid’s load from the disturbance (and thereby maintaining service) without harming the transmission grid’s integrity.

The difficult task is to achieve this functionality without extensive custom engineering and still have high system reliability and generation placement flexibility. To achieve this we promote a peer-to-peer and plug-and-play model for each component of the microgrid. The peer-to-peer concept insures that there are no components, such as a master controller or central storage unit that is critical for operation of the microgrid. This implies that the microgrid can continue operating with loss of any component or generator. With one additional source (N+1) we can insure complete functionality with the loss of any source. Plug-and-play implies that a unit can be placed at any point on the electrical system without re-engineering the controls.

Plug-and-play functionality is much akin to the flexibility one has when using a home appliance. That is it can be attached to the electrical system at the location where it is needed. The traditional model is to cluster generation at a single point that makes the electrical application simpler. The plug-and-play model facilitates placing generators near the heat loads thereby allowing more effective use of waste heat without complex heat distribution systems such as steam and chilled water pipes.

This ability to island generation and loads together has the potential to provide a higher local reliability than that provided by the power system as a whole. Smaller units, having power ratings in thousands of watts, can provide even higher reliability and fuel efficiency. These units can create microgrid services at customer sites such as office buildings, industrial parks and homes. Since the smaller units are modular, site management could decide to have more units (N+) than required by the electrical/heat load, providing local, online backup if one or more of the operating units failed. It is

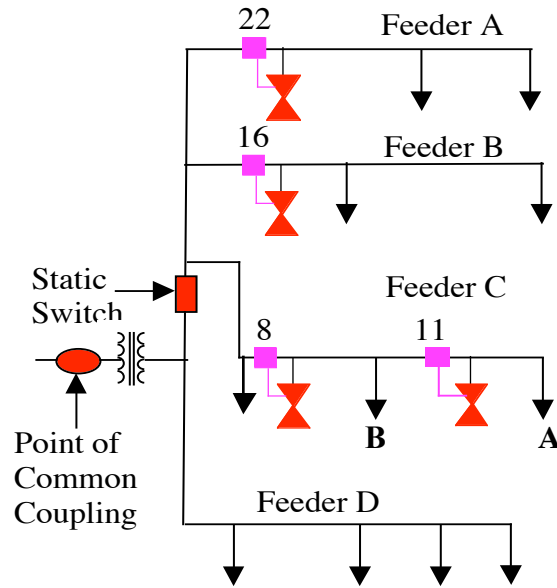

Figure 2 Microgrid

also much easier to place small generators near the heat loads thereby allowing more effective use of waste heat.

Basic Microgrid architecture is shown in figure 2. This consists of a group of radial feeders, which could be part of a distribution system or a building’s electrical system. There is a single point of connection to the utility called point of common coupling. Some feeders, (Feeders A-C) have sensitive loads, which require local generation. The non-critical load feeders do not have any local generation. In our example this is Feeder D. Feeders A-C can island from the grid using the static switch which can separate in less than a cycle [5]. In this example there are four microsources at nodes 8, 11, 16 and 22, which control the operation using only local voltages and currents measurements. When there is a problem with the utility supply the static switch will open, isolating the sensitive loads from the power grid. Feeder D loads ride through the event. It is assumed that there is sufficient generation to meet the loads’ demand. When the Microgrid is grid-connected power from the local generation can be directed to feeder D.

## V. MICROGRID CONTROL

Inverters can provide the control and flexibility required for plug-and-play functionality. Microgrid controls need to insure that; new microsources can be added to the system without modification of existing equipment, the Microgrid can connect to or isolate itself from the grid in a rapid and seamless fashion, reactive and active power can be independently controlled, and can meet the dynamic needs of the loads

Microsource controller techniques described below rely on the inverter interfaces found in fuel cells, microturbines, and storage technologies. A key element of the control design is that communication among microsources is unnecessary for basic Microgrid operation. Each microsource controller must be able to respond effectively to system changes without requiring data from the loads or other sources.

Operation of the Microgrid assumes that the power electronic controls of current microsources are modified to provide a set of key functions, which currently do not exist. These control functions include the ability to; regulate power flow on feeders; regulate the voltage at the interface of each microsource; ensure that each microsource rapidly pickups up its share of the load when the system islands. In addition to these control functions the ability of the system to island smoothly and automatically reconnect to the bulk power system is another important operational function. Figure 3 is a block diagram of the microsource controller. The critical system performance components are the voltage versus reactive power droop and power versus frequency droop.

### Voltage vs. Reactive Power (Q) Droop

Integration of large numbers of microsources into a Microgrid is not possible with basic unity power factor controls. Voltage regulation is necessary for local reliability and stability. Without local voltage control, systems with high penetrations of microsources could experience voltage and/or reactive power oscillations. Voltage control must also insure that there are no large circulating reactive currents between sources. With small

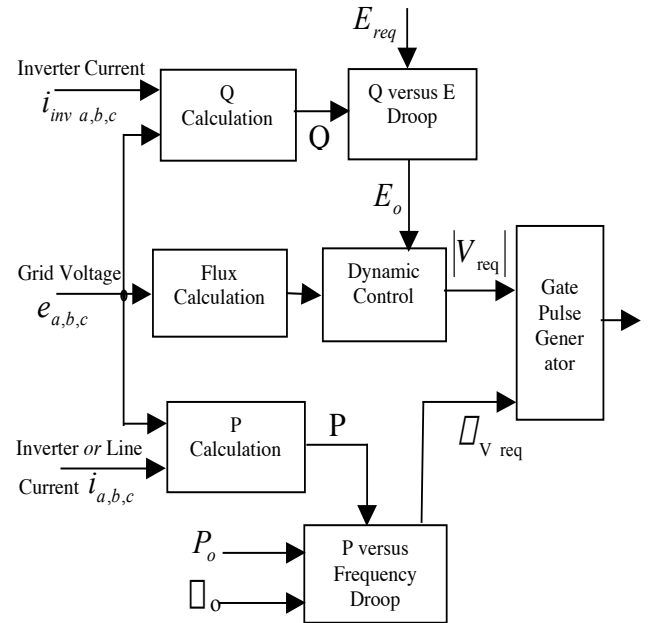

Figure 3 Microsource Controller

errors in voltage set points, the circulating current can exceed the ratings of the microsources. This situation requires a voltage vs. reactive power droop controller so that, as the reactive power generated by the microsource becomes more capacitive, the local voltage set point is reduced. Conversely, as Q becomes more inductive, the voltage set point is increased.

### Power vs. Frequency Droop

Microgrids can provide premium power functions using control techniques where the Microgrid can island smoothly and automatically reconnect to the bulk power system, much like a UPS system. In island mode, problems from slight errors in frequency generation at each inverter and the need to

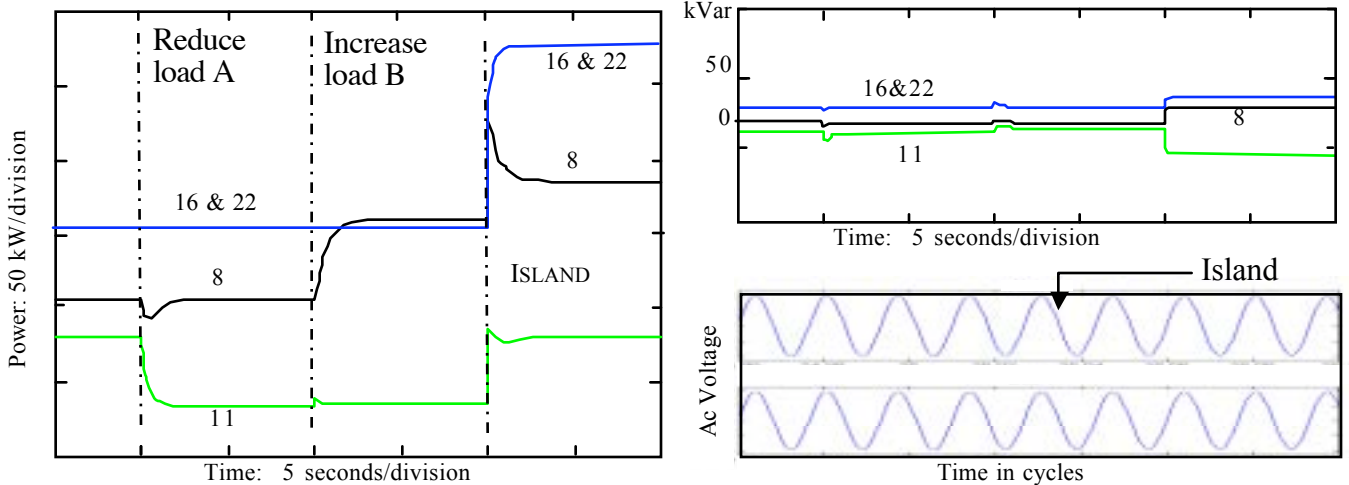

Figure 4 Dynamics of Test Microgrid

change power-operating points to match load changes need be addressed. Power vs. frequency droop functions at each microsource can effectively solve these problems without a communication network. When the Microgrid is connected to the grid, Microgrid loads receive power both from the grid and from local microsourses, depending on the customer's situation. If the grid power is lost because of voltage drops, faults, blackouts, etc., the Microgrid can transfer smoothly to island operation. When the Microgrid separates from the grid, the voltage phase angles at each microsource in the Microgrid change, resulting in an apparent reduction in local frequency. This frequency reduction coupled with a power increase allows for each microsource to provide its proportional share of power.

## VI. DYNAMIC SYSTEM EXAMPLE

An industrial plant with dynamic loads can be used to illustrate the dynamics of the Microgrid controls presented in the previous section, see figure 2 for a simplified layout. This industrial site has nearly 1.2 MWs of load with motors and a 120-kV grid supply which provides power through a long 13.8-kV feeder consisting of overhead lines and underground cables. The plant has four main feeders at 480V. The loads on three 480-V feeders are critical and must be continually served if grid power is lost. These three feeders have microsourses at nodes 8, 11, 16, and 22 and the ability to island using a static switch. The fourth feeder stays connected to the grid. Sources at nodes 16 and 22 are on separate radial feeders while sources at nodes 8 and 11 are on the same radial feeder separated by 200 meters of cable. Load A is near node 11 while load B is between nodes 8 and 11. Figure 4 illustrates the response of the four sources to a sequence of three events; reduction of load A; followed by an increase of load B; and islanding. The "boxes" under 22, 16, 11, and 8 also regulate the power flow in the feeder to a dispatched level. The plot on the left of figure 4 is the output power of each source for the three events. A load reduction at A results in a decrease in power flow at 8 and 11. This results in a new operating point for source 11 to hold the power flowing into feeder C constant. The second event is an increase in load at B. This results in an increase power output from source 8. At the point of islanding all four sources increase their output to make up the loss of power from the grid. The top left hand plots in figure 4 are the reactive power outputs from each machine. In the absents of the voltage vs. reactive power droop these values would be more than ten times larger. The lower left curves are the voltages at 8 and 11 during loss of the utility grid.

## VII. CASE STUDY

These simulations have been verified in a laboratory-scale microgrid at the University of Wisconsin-Madison. The experimental results are used to further refine the control algorithms and iterate on the best possible approach to achieve objectives for the Microgrid. The system has been designed to provide maximum flexibility with a variety of loads to study

the operation of the systems under various operating scenarios. Each microsource consist of a dc power supply, a dc bus and voltage sourced inverter coupled to the ac grid through a LC filter, transformer and large inductance. The transformer and inductor are sized to insure that the voltage angle across the inductance is  $10^\circ$  at full power. This provides an excellent emulation of microturbines and fuel cell systems with storage on dc bus [6]. The experimental system features: • Multi-DG sources • A directly interfaced DG system • A transformer-coupled DG system • Test island operation • Induction motor loads • Adjustable-speed drive loads • Four wire systems • Single-phase loads • Digital signal processing platform • AC-side capacitor banks.

The test system configuration is a single feeder with two sources and three loads. It is equivalent to Feeder C in figure 2 including the static switch and transformer. The source near the static switch is labeled DR-1. There are three loads, one at each source and a third between the two sources, (load B). The two sources are separated by 100 yds of 4 wire cable to provide the necessary voltage drop that could be experienced in a actual applications. The connecting transformer has a

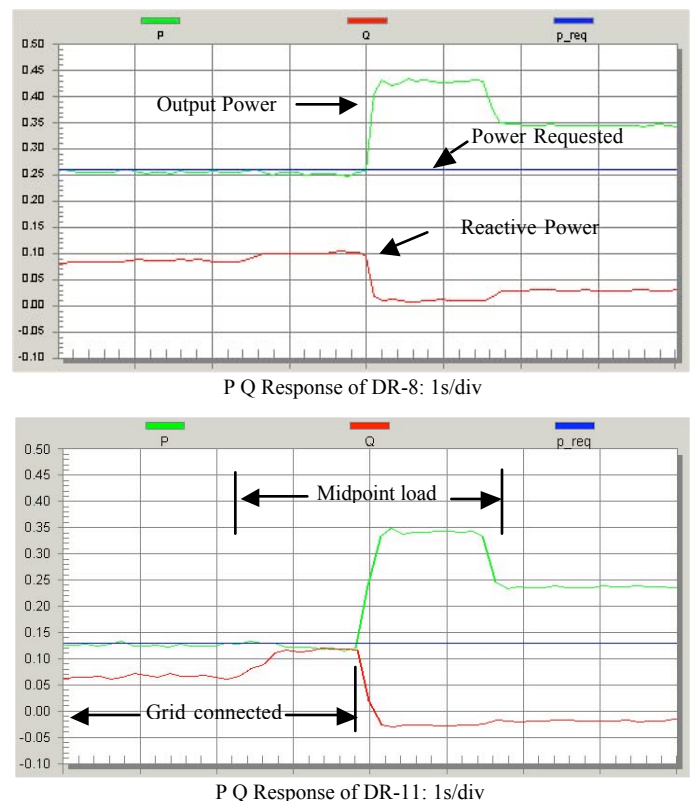

Figure 5 Real and Reactive Power Response for DR-8 and DR-11

480V primary with a 208V secondary. The study has three events; add a midpoint load B, while grid connected, disconnect from the grid and removal of the midpoint load while islanded. In this case study the power output from the DR units are regulated not the feeder power as illustrated in

Section VI. The PQ response for DR-8 and DR-11 is shown in figure 5. Figure 6 shows the currents provided by the grid and DR-8, the current flowing into the feeder below DR-8, and the voltage at the midpoint load. When the midpoint load is added figure 5 shows no change in the power output of DR-8 and DR-11 with the load being supplied by the grid as shown in figure 6. When the system islands DR-8 and DR-11 increase their power output to make up for the loss of grid power. This increase is a function of the power vs. frequency droop circuit in each controller. Also note that the reactive power is reduced since there is no longer any need to support the grid's feeder voltage. Figure 6 also demonstrates the stability of the load voltage is during these events events.

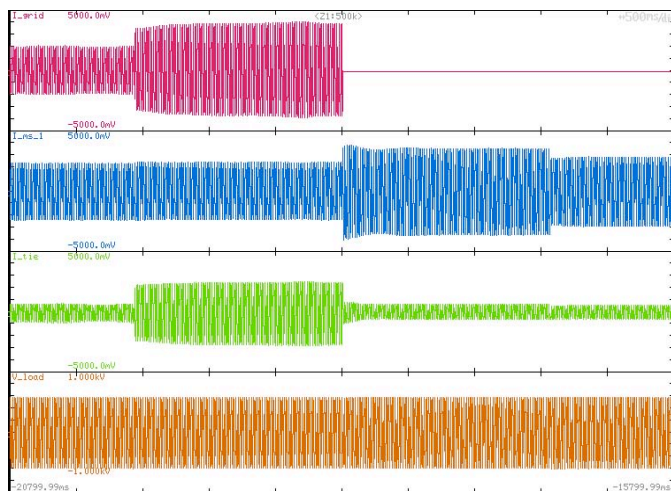

Figure 6 Current from Grid, DR-8 & Feeder: Voltage at Midpoint

## VIII. CONCLUSION

The work on the Microgrid has progressed well. Currently with support from California Energy Commission in conjunction with CERTS we are starting the design and construction of a full scale Microgrid. This Microgrid will be constructed and tested at a utility site. This test site will include three 60kW microturbines.

## IX. ACKNOWLEDGMENT

This work was supported in part by the U.S. Department of Energy (DE-A103-01SF22333), Power System Research Center, National Renewable Energy Laboratory (AAD-1-30605-14) and the California Energy Commission (150-99-003).

## REFERENCES

- [1] M. Valenti "Reaching for 60 percent, the General Electric H turbine system taking shape in Wales is making a bid for a new record in thermal efficiency." Mechanical Engineering, April 2002.
- [2] Colleen Williams, "CHP Systems," Distributed Energy, March/April 2004, pp.57-59.
- [3] Office of Energy Efficiency and Renewable Energy, U.S. Department of Energy, "2001 BTS Core Databook," Office of Building Technology, July 13, 2001
- [4] Lasseter, R., "MicroGrids," IEEE PES Winter Meeting, January 2002
- [5] Zang, H., M.Chandorkar, G. Venkataramanan, "Development of Static Switchgear for Utility Interconnection in a Microgrid." Power and Energy Systems PES, Feb. 24-26, 2003, Palm Springs, CA.
- [6] Illindals, M., G. Venkataramanan, "Battery Energy Storage for Stand-Alone Micro-Source Distributed Generating System," 6<sup>th</sup> IASTED Intl. Conf. On power and Energy Systems.

**Robert H. Lasseter** (F92) received the Ph.D. in Physics from the University of Pennsylvania, Philadelphia in 1971. He was a Consulting Engineer at General Electric Co. until he joined the University of Wisconsin-Madison in 1980. His research interests focus on the application of power electronics to utility systems and technical issues which arise from the restructuring of the power utility system. This work includes interfacing micro-turbines and fuel cells to the distribution grid, control of power systems through FACTS controllers, use of power electronics in distribution systems and harmonic interactions in power electronic circuits. Professor Lasseter is a Fellow of IEEE, an expert advisor to CIGRE SC14.

**Paolo Piagi** obtained his B.S. and M.S. in Electrical Engineering at the Polytechnic of Turin, in Italy. He is currently pursuing his Ph.D. in EE at the University of Wisconsin-Madison under the supervision of Professor R.H. Lasseter. Here Paolo developed a control for distributed resources. He then implemented his design on DSP and is now involved in testing it in a lab scale microgrid.